

grande
brio



ecoray
ecoray

INNOVATION IN CLEANING EQUIPMENT
TSM

35 B & (E)

75 - 650

Szerokość czyszczenia / Scrubbing path	mm	350	650
Szerokość ssawy / Squeegee width	mm	420	750
Wydajność czyszczenia / Coverage performance	m ² /h	1050	3250
Czas pracy baterii / Working time	h	> 1h 30', (∞)	> 3h
Zbiorniki Roztworu-Zwrotny / Solution-Recovery tanks	l	16 / 18	75 / 85
Średnica szczotki / Brush size	mm	1 x 350	4 x 180
Moc silnika szczotki / Brush motor	W, V	1 x 250	4 x 100, 24
Nacisk szczotki / Brush pressure	kg	28	28
Moc silnika jazdy / Traction motor	W, V	//	700, 24
Moc agregatu ssącego / Vacuum motor	W, V	2 stages 200 (210), 12 (220)	3 stages 530, 24
Ecoray® moc systemu / Ecoray® system power	µW/cm ²	100	100
Czas pracy źródła UV / Life time UV source	h	9000	9000
Pojemność baterii (DIN) / Battery capacity (DIN)	A (5h)	65 (Gel), (//)	150 (Wet)
Wymiary skrzyni baterii (LxLxH) / Batt. comp. (LxWxH)	mm	290 x 190 x 235, (//)	400 x 420 x 325
Ładowarka / Battery charger	A/h	8 (on board), (//)	20
Ciężar bez (z) baterii / Weight without (with) batteries	kg	40 (63,5)	158 (235)
Wymiary Maszyny (LxLxH) / Dimensions (LxWxH)	mm	770 x 460 x 645	1150 x 780 x 1300

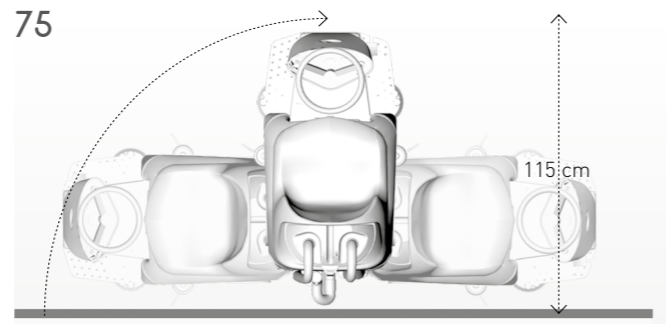
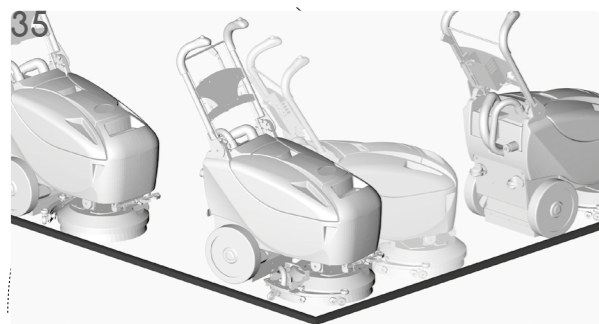

ecoray®

jest zintegrowanym systemem do sterylizacji, który umożliwia wyeliminowanie 99% bakterii, które znajdują się na podłodze, bez użycia środków chemicznych

is the integrated sterilization system that allows the elimination of 99% of bacteria presented on the floor, without using chemicals



To jest czas na krok do przodu, podejmij wyzwanie. To jest czas dla GRANDE BRIO

Sukces dzięki prostocie



INNOVATION IN CLEANING EQUIPMENT

TSM